

DMX-Basic



Instruction

REF 2100094-1/09.10-ENG



English

Medical devices entirely made in Switzerland by Bien-Air Dental SA.

Type

Electronic control for Bien-Air Dental MX induction micromotors. Brushless micromotors without sensors, with current limiting function.

Intended use

Product intended for professional use only. Use in dentistry for prophylaxis, general dentistry and endodontic work.

Technical data

Classification

Class IIa in accordance with European Directive 93/42/EEC concerning medical devices.

Dimensions

127 x 58 x 34 mm (y.c. blue connector)

Weight

approx. 150 g

Voltage

32 Vdc ±10%

Description

For device references, see fig. 1 ⑤ and ⑥.
MX system: consists of an MX motor, 4VX hose, and DMX-B electronic control.

Current limitation

Micromotor MX: 4.2 A

Transformer nominal power rating

60 VA, peak power 120 VA

Connectors and wiring diagram

see fig. 1 and fig. 2.

- ① Feed voltage
- ② Air pressure sensor
- ③ DIP switches
- ④ Optional I/O

The general wiring diagram shows all the main connections of the complete MX system. The connections actually required depend on the integration of the MX system in the unit and the desired functions fig. 2.

The table fig. 3 describes the main characteristics of each connection described in the wiring diagram.

Main functions and controls

- Pneumatic control.
- Electric control by analogue inputs or digital interface (RS-232)
- Control with up to two MX motors (using Dual Motor Switch REF 1500554)
- Control with up to one solenoid valve (EV) for cooling air
- The system variable parameters are as follows:
 - Speed range 100 - 40,000 rpm (maximum torque of over 3.0 Ncm available across the full speed range)
 - Progressive or ON/OFF mode speed adjustment
 - Brightness control (16 settings) or light ON/OFF
 - Reversal of rotation direction (clockwise/anti-clockwise)

For more information on integrating the MX system in the dental unit, examples of integration and technical support, please contact your Bien-Air Dental dealer.

Precautions to be taken during integration

- Link the earths of all the electronic controls connected to the DMX. This also applies to digital interfaces.
- The 24 Vdc feed is only required when using solenoid valve outputs and/or the MUX OUT output.
- The motor light should be fed from the DMX. Do not use any other feed for the light, as this may impair motor operation.
- The output for operating the solenoid valve is only active while the motor is operating (if digital interfaces are being used, the output can be actuated at any time).
- The input voltage levels can be configured via the RS-232 serial interface (document available on request).
- If you have any questions regarding MX system integration, configuration, wiring or programming, please contact your Bien-Air Dental dealer.

Protection installed

Temperature

- The motor outer surface and electronic control temperatures are continuously controlled by the system.

Power supply

- The electronic control system is protected against over- and undervoltage, and also against short circuits on the feed input.

Motor and light

- The motor output (phases) is protected against short circuits.
- The light output is protected against short circuits.
- Interruption of one, two or three phases is detected by the system, and the motor either does not start or stops.

Exhaust air

REF 249.39.11: this system is only necessary if the device is pneumatically-controlled, with the air pedal in the raised position, and if the valve controlled by the pedal is not fitted with a vent. Contact your dealer for fitting.

Transport and storage

Environmental conditions (max. 15 weeks)
Temperature: -25°C to +70°C
Relative humidity: 10% to 95%
Atmospheric pressure: 500 hPa to 1060 hPa

Standards

This electronic control conforms to electrical safety standards in line with standard IEC 60601-1 and those governing electromagnetic compatibility in line with standard IEC 60601-1-2.

Options

Converter 24/32-24 REF 1500580-001

The DMX is fed by 32 Vdc +/-10%. If your system only has a 24 Vac feed, we recommend that you use this converter. This accessory enables you to obtain optimum performance from the MX system, by providing two stabilised voltages: 32 Vdc (60W continuous, 120W peak) for the MX motor feed and 24 Vdc (12W continuous, 24W peak) for the solenoid valve and relay feeds.

Dual Motor Switch REF 1500554-001

We recommend this module when using 2 MX motors with a DMX board. It allows switching of the 3 motor phases, the 2 light connections and a solenoid valve for cooling air. The relays are switched simultaneously and controlled by the MUX Control input (24 Vdc). To connect this electronic control to the MX system, please consult the wiring diagram.

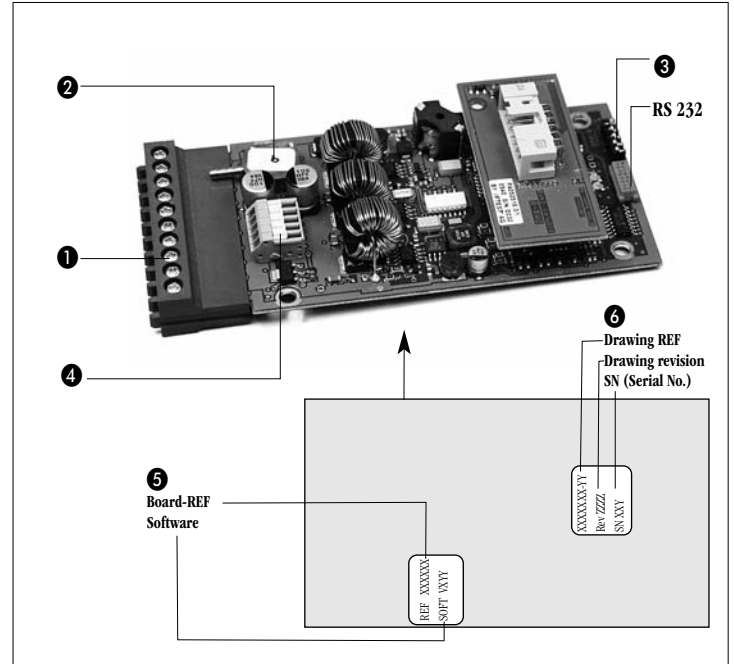

fig. 1

Operating mode selection by DIP-Switches

The 4 DIP-Switches are used to configure the system, and in particular to select the operating mode (see table below). For more information and technical support, please contact your Bien-Air Dental dealer.

DIP-Switches			
1	2	3	4
Lighting timer		Mode	

DIP Switch 1: Lighting timer: OFF = the light is lit continuously.
ON = the light goes out 10 seconds after the motor stops (except in serial mode).

DIP Switches 2, 3 and 4: See table below

The serial mode protocols for mode 3 are available on request from your Bien-Air Dental dealer.

Mode	Binary			Description
	2	3	4	
0	OFF	OFF	OFF	Pneumatic mode with a max. speed of 40,000 rpm
1	OFF	OFF	ON	Pneumatic mode with a max. speed of 6,000 rpm
2	OFF	ON	OFF	Pneumatic mode with electric limitation
3	OFF	ON	ON	Serial mode (RS232)
4	ON	OFF	OFF	Electric mode from 100 rpm to 40,000 rpm
5	ON	OFF	ON	Electric mode from -40,000 rpm to 40,000 rpm
6	ON	ON	OFF	Electric log mode from 100 rpm to 40,000 rpm
7	ON	ON	ON	Pneumatic mode with electric log limitation

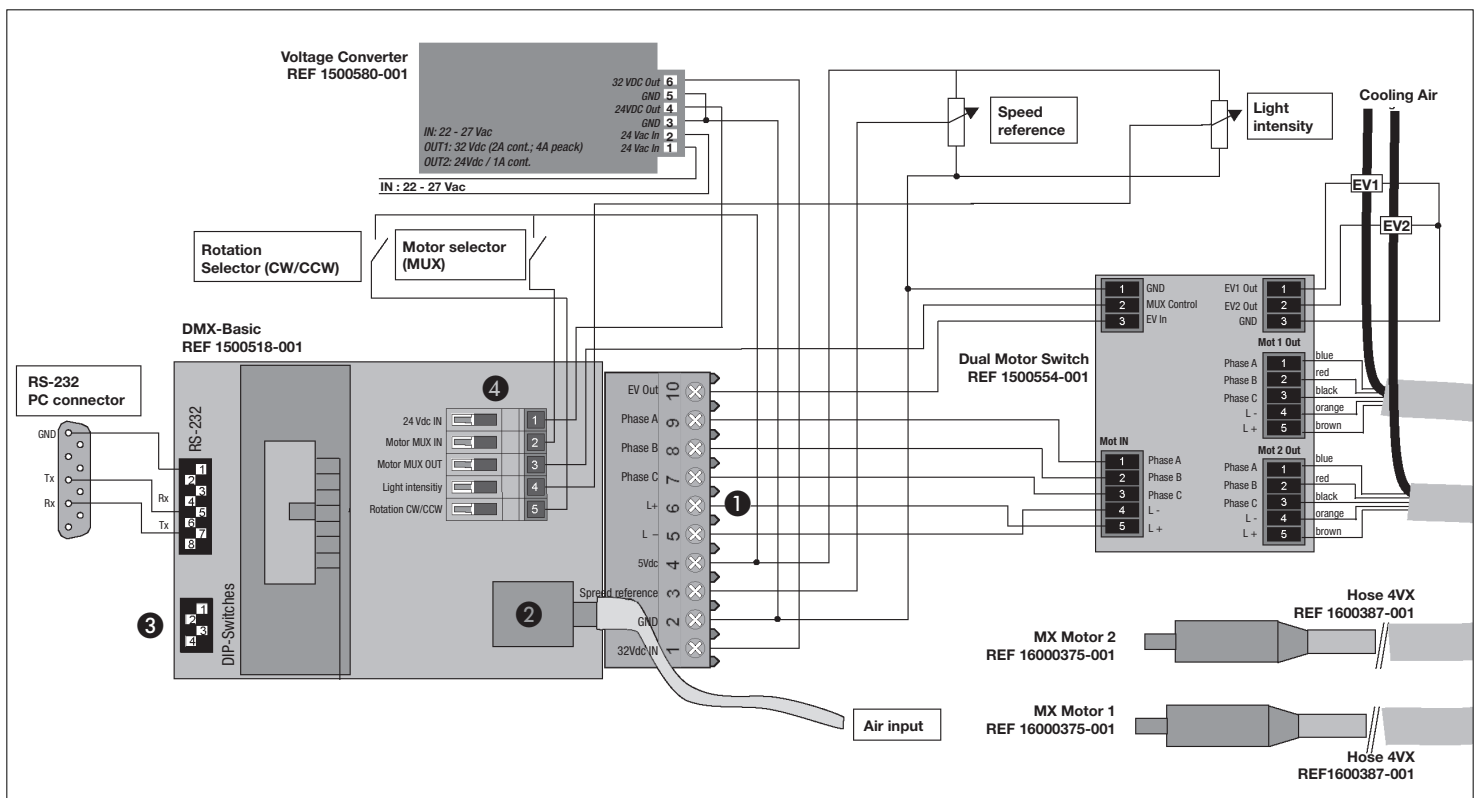

fig. 2

Description	Diagram ref.	Specification	Notes
DMX-Basic REF 1500518-001			
Voltage	Input	32 Vdc +/- 10% 24 Vdc +/-10%	
Speed reference	Input	0 to 5 Vdc (linear or logarithmic)	Pull-down Input
MUX IN motor	Input	0 or 5 Vdc (TTL)	Pull-down Input
Rotation (CW/CCW)	Input	0 or 5 Vdc (TTL)	Pull-down Input
Brightness	Input	0 to 5 Vdc (16 output levels)	Pull-up Input
Pneumatic pressure reference	Input	0 to 3 bar (0 to 300 kPa, 14.5 to 43.5 psi)	
Motor Power	Output	Phases A, B, and C	
Motor Light	Output	L + / L-	
MUX OUT motor	Output	24 Vdc, Max. current = 100mA	
EV Out	Output	24 Vdc, Max. current = 100mA	
RS-232		Digital interface	
Voltage converter REF 1500580-001			
Voltage	Input	22 to 27 Vac or 22 to 37 Vdc	
Voltage	Output	24 Vdc (24W peak / 12W cont)	
Voltage	Output	32 Vdc (130W peak / 60W cont)	
Dual Motor Switch REF 1500554-001			
IN motor	Input	3 motor phases: A, B, C (Max. current = 6A) 2 light connections L+, L- (Max. current = 3A)	Max. relay current
MUX control	Input	24 Vdc, 200 mW	Max. relay current
EV In	Input	Solenoid valve input (24 Vdc)	
OUT motor 1	Output	3 motor phases A, B, C (Max. current = 6A) 2 light connections	Max. relay current
OUT motor 2	Output	3 motor phases: A, B, C (Max current = 3A) 2 light connections	Max. relay current
EV1 Out	Output	Motor 1 solenoid valve output (24 Vdc)	
EV2 Out	Output	Motor 2 solenoid valve output (24 Vdc)	

fig. 3

Maintenance

Servicing

Never disassemble the device. For any modification and repair, we recommend that you contact your regular supplier or Bien-Air Dental directly. Bien-Air Dental asks the user to have its dynamic instruments checked or inspected at least once a year.

Information

The technical specifications, illustrations and dimensions contained in these instructions are given only as a guide. They may not be the subject of any claim. The manufacturer reserves the right to make technical improvements to its equipment, without amending these instructions. For all additional information, please contact Bien-Air Dental SA at the address indicated on the back cover.

This device must be recycled. Electrical and electronic equipment may contain dangerous substances which constitute health and environmental hazards. The user must return the device to its dealer or establish direct contact with an approved body for treatment and recovery of this type of equipment (European Directive 2002/96/EC).

General information

The device must be used by a qualified person in accordance with the current legal provisions concerning industrial safety, health and accident prevention measures, and these working instructions. In accordance with these requirements, the operators:

- must only use operating devices that are in perfect working order; in the event of irregular functioning, excessive vibration, abnormal heating or other signs indicating malfunction of the device, the work must be stopped immediately; in this case, contact a repair centre that is approved by Bien-Air Dental;
- must ensure that the device is used only for the purpose for which it is intended, must protect themselves, their patients and third parties from any danger, and must avoid contamination through the use of the product.

The device is intended for medical treatment only; any use other than that for which this product is intended is unauthorised and may be dangerous. The medical device meets all the current legal requirements.

The device is not authorised for use in an explosive atmosphere (anaesthetic gas).

Avoid any contact with liquids.

Only use maintenance products and components from Bien-Air Dental. The use of other products and components can void the guarantee.

Guarantee

Terms of guarantee

Bien-Air Dental grants the user a guarantee covering all functional defects, material or production faults. The device is covered by this guarantee for 12 months from the date of invoicing.

In the event of justified claim, Bien-Air Dental or its authorised representative will fulfil the company's obligations under this guarantee by repairing or replacing the product free of charge. Any other claims, of whatever nature, in particular in the form of a claim for damages and interest, are excluded.

Bien-Air Dental shall not be held responsible for damage or injury and the consequences thereof, resulting from:

- excessive wear and tear
- improper use
- non-observance of the instructions for installation, operation and maintenance
- unusual chemical, electrical or electrolytic influences
- poor connections, whether of the air, water or electricity supply.

The guarantee does not cover flexible "fibre optic" type conductors, or any parts made of synthetic materials.

The guarantee shall become null and void if the damage and its consequences are due to improper manipulation of the product, or modifications to the product carried out by persons not authorised by Bien-Air Dental.

Claims under the terms of the guarantee will be considered only on presentation, together with the product, of the invoice or the consignment note, on which the date of purchase, the product reference and the Serial No. should be clearly indicated.

Recommended separation distances between portable and mobile RF communications equipment and the DMX

The DMX is intended for use in an electromagnetic environment in which radiated RF disturbances are controlled. The customer or the user of the DMX can help prevent electromagnetic interference by maintaining a minimum distance between portable and mobile RF communications equipment (transmitters) and the DMX as recommended below, according to the maximum output power of the communications equipment.

Rated maximum output power of transmitter W	Separation distance according to frequency of transmitter m		
	150 kHz to 80 MHz $d=1,2 \sqrt{P}$	80 MHz to 800 MHz $d=1,2 \sqrt{P}$	800 MHz to 2,5 GHz $d=23 \sqrt{P}$
0,01	0,12	0,12	0,23
0,1	0,38	0,38	0,73
1	1,2	1,2	2,3
10	3,8	3,8	7,3
100	12	12	23

For transmitters rated at a maximum output power not listed above, the recommended separation distance d in metres (m) can be estimated using the equation applicable to the frequency of the transmitter, where P is the maximum output power rating of the transmitter in watts (W) according to the transmitter manufacturer.

NOTE 1: At 80 MHz and 800 MHz, the separation distance for the higher frequency range applies.

NOTE 2: These guidelines may not apply in all situations. Electromagnetic propagation is affected by absorption and reflection from structures, objects and people.

REF Legend

1600743-001	Set DMX-B
1500518-001	Electronic DMX-B
1302410-001	Upper cover
1302411-001	Lower cover
1500554-001	Dual Motor Switch
1500579-001	Cable RS-232
1500580-001	Converter 24/32 Vdc and 24 Vdc
249.39.11-001	Exhaust air

List of Bien-Air Dental SA registered trademark products ®:

Aquilon®	Gyro®	PowerCare®
Bora®	Gyrolina®	Prestilina®
Boralina®	Isolite®	Spraynet®
ChiroPro®	Lubrifluid®	
Diamline®	Lubrimed®	
Eolia®	MX®	

In these instructions, "Device" corresponds to the product described in the heading "Type". For example, turbine, contra-angle, handpiece, micromotor, tube, electronics, connectors, station etc.

This product may be covered by one or more of the following patents:

EP Europe: 0 497 139 / 0 526 783 / 0 745 358 / 0 688 539 / 0 894 879 / 1 145 688 / 1 109 301 **DE Germany:** 296 16 023.7
DK Denmark: 96 00315 **FR France:** 2 679 804 / 2 722 972 / 2 733 680 / 2 692 621 / 2 720 263 / 2 757 763 / 2 766 697 / 2 781 318
CH Switzerland: 693 922 **CN China:** 129343 **JP Japan:** 2 037 611 / 1 991 770 **US United-States:** 5.059.122 / 4.773.856 / 6.033.220 / 6.337.554 / 5.453.008 / 6.319.003 / 6.495.937

REF 1600473-001 BOARD DMX-B

Set supplied

Set REF 1600473-001 :



REF 1500518 DMX-B

REF 1302410



REF 1302411

Optional accessories



REF 1500580-001



REF 1500554-001



REF 1500579-001

Bien-Air Dental SA

Länggasse 60
Case postale
2500 Bienne 6, Switzerland
Tel. +41 (0)32 344 64 64
Fax +41 (0)32 344 64 91
office@bienair.com

Bien-Air Deutschland GmbH

Jechtinger Strasse 11
79111 Freiburg, Deutschland
Tel. +49 (0)761 45 57 40
Fax +49 (0)761 47 47 28
ba-d@bienair.com

Bien-Air España SA

Entença, 169 Bajos
08029 Barcelona, España
Tel. +34 934 25 30 40
Fax +34 934 23 98 60
ba-e@bienair.com

Bien-Air USA, Inc.

Medical Technologies
5 Corporate Park
Suite 160
Irvine, CA 92606 USA
Phone 1-800-433-BIEN
Phone 949-477-6050
Fax 949-477-6051
ba-usa@bienair.com

Bien-Air France Sàrl

55-57, avenue Jean Lolive
93508 Pantin Cedex, France
Tel. +33 (0)1 41 83 60 70
Fax +33 (0)1 48 96 07 40
ba-f@bienair.com

Bien-Air Italia s.r.l.

Via Vaina 3
20122 Milano, Italia
Tel. +39 (02) 58 32 12 51/52/54
Fax +39 (02) 58 32 12 53
ba-i@bienair.com

Bien-Air UK Limited

63, The Street Chapel,
Surrey RH5 5JZ, England
Tel. +44 (0)1306 711 303
+44 (0)1306 712 505
Fax +44 (0)1306 711 444
ba-uk@bienair.com

Bien-Air Asia Ltd.

Nishi-Ikebukuro
Daiichi-Seimei Bldg. 10F
2-40-12 Ikebukuro, Toshimaku
Tokyo, 171-0014, Japan
ピエン・エア・アジア株式会社
〒171-0014
東京都豊島区池袋2-40-12
西池袋第一生命ビルディング10F
Tel. +81 (3) 5954-7661
Fax +81 (3) 5954-7660
ba-asia@bienair.com

Beijing Bien-Air

Medical Instrument
Technology Service Co. Ltd.
Room 907, The Exchange Beijing,
No 118 Jian Guo Lu Yi,
Chao Yang District,
Beijing 100022, China
北京彼岸医疗器械
技术服务有限公司
北京市朝阳区建国路
乙118号招商局中心
京汇大厦2106室
Tel. +86 10 6567 0651
Fax +86 10 6567 8047
ba-beijing@bienair.com